

## Mobil Tekerlekli İskele Sistemi

Mobile (Wheeled) Scaffolding System





### Mobil Tekerlekli İskele Sistemi

İki kişi ile kolayca kurulur. Pano, çapraz bağlantı ve çalışma platformundan oluşur. Çalışma alanına ulaşım iskele içi merdiven veya asma merdiven (gemici merdiveni) ile sağlanır. Çalışma yüksekliğine göre değişik ölçüleriniz projelendirilir ve üretilir. Panolar 8 mt çalışma yüksekliğine kadar 38\*2 mm, üzeri yüksekliklerde 42\*2,5 mm ve çapraz bağlantılar 27\*2,5 mm TSE Belgeli, mekanik testlere tabi tutulmuş, standart bonulardan üretilir. Üretimlerimizde otomatik gazaltı kaynak makineleri kullanılır. Sistem 2 kat rapid boyalıdır, talep halinde galvaniz ile de kaplanır.

### Mobile (Wheeled) Scaffolding System

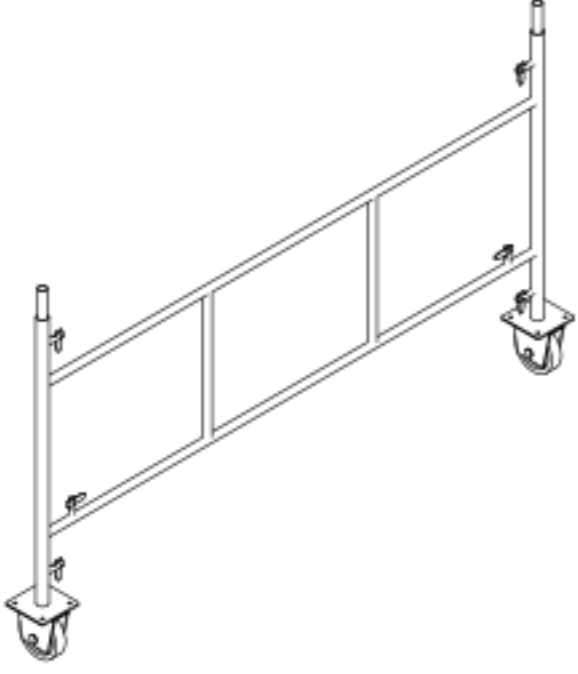
It is easily erected by 2 persons. It is consisted of frame, diagonal brace and steel deck. Access to the working area is provided by ladder or access ladder. Different heights are designed and manufactured produced 38\*2 mm pipes until 8 m height. On the 8 meter height 42\*2,5 mm pipes are used. Diagonal braces are produced 27\*2,5 mm pipes. We use automatic arc welding in the manufacturing process. The system has special antirust paint and if required galvanized.

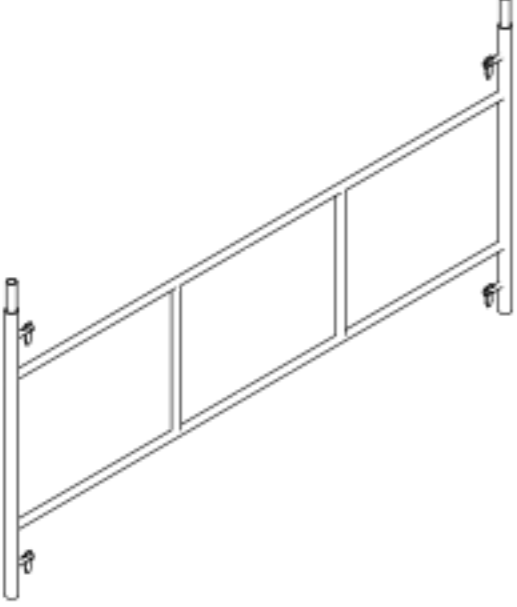
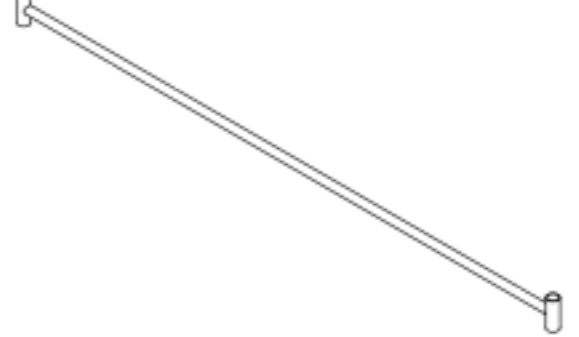
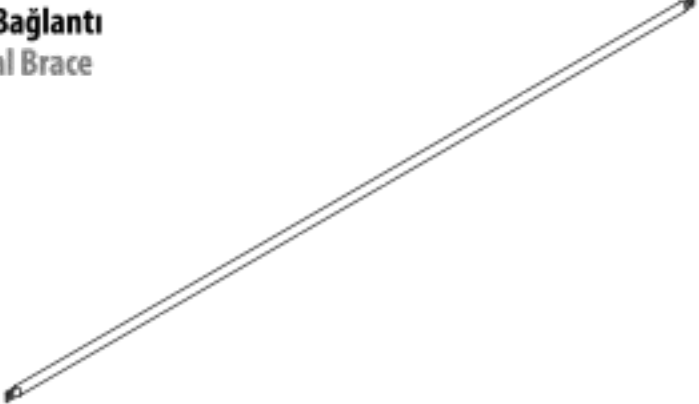
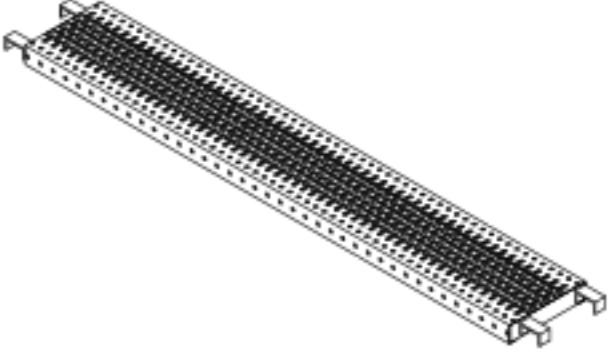
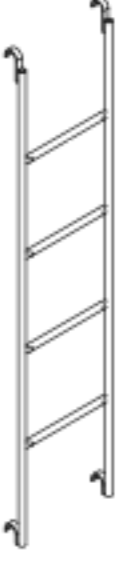
	AĞIRLIK KG WEIGHT KG	UZUNLUĞU LENGTH	ÜRÜN KODU CODE		AĞIRLIK KG WEIGHT KG	UZUNLUĞU LENGTH	ÜRÜN KODU CODE	
<b>Tekerlekli Pano</b> Wheeled Frame 	15,00	150*100	180101		2,40	38	180401	<b>Korkuluk Dikey Elemanı</b> Vertical Guard Rail 
	17,40	200*100	180102		3,00	42	180402	
	20,90	250*100	180103					
	23,10	300*100	180104					
<b>Pano</b> Frame 	10,00	150*100	180201		2,90	150	180501	<b>Korkuluk Yatay Elemanı</b> Horizontal Guard Rail 
	12,40	200*100	180202		3,60	200	180502	
	15,90	250*100	180203		4,40	250	180503	
	18,10	300*100	180204		5,10	300	180504	
<b>Çapraz Bağlantı</b> Diagonal Brace 	10,50	30*150	210701		10,50	30*150	210701	<b>Çelik Platform</b> Steel Deck 
	13,50	30*200	210702		13,50	30*200	210702	
	16,00	30*250	210703		16,00	30*250	210703	
	21,00	30*300	210704		21,00	30*300	210704	
<b>Asma Merdiven 45*150</b> Access Ladder 45*150 	9,00		210901		2,80	150	180301	
					3,40	200	180302	
					4,10	250	180303	
					4,80	300	180304	